

Asterfusion ET2500

Open Intelligent Gateway



Overview

The Asterfusion ET2500 is an open intelligent gateway designed to address the intricate networking requirements of modern enterprises. It uses Marvell OCTEON 10 CN102XX chip. This Computing-Networking fusion chip integrates an 8-core ARM 64-bit Neoverse N2 processor, programmable Ethernet switch ports with total throughput of 60 Gbps, and an embedded encryption/decryption engine with a processing capacity of 60 Gbps. Combined with optimized DPDK toolkits bound to these hardware components and an optional AI hardware accelerator capable of up to 26 TOPS, it enables full-stack analysis and intelligent processing of network traffic from the network layer to the application layer. Additionally, the ET2500 supports installation of various Linux distributions, including Ubuntu, Debian, OpenWRT and CentOS, fostering an open software ecosystem that includes VPP, UFW, OpenVPN, Snort, HAProxy, Nginx, ntopng, and others. Users can run multiple applications simultaneously on the single intelligent device, replacing the need for multiple dedicated hardware devices.

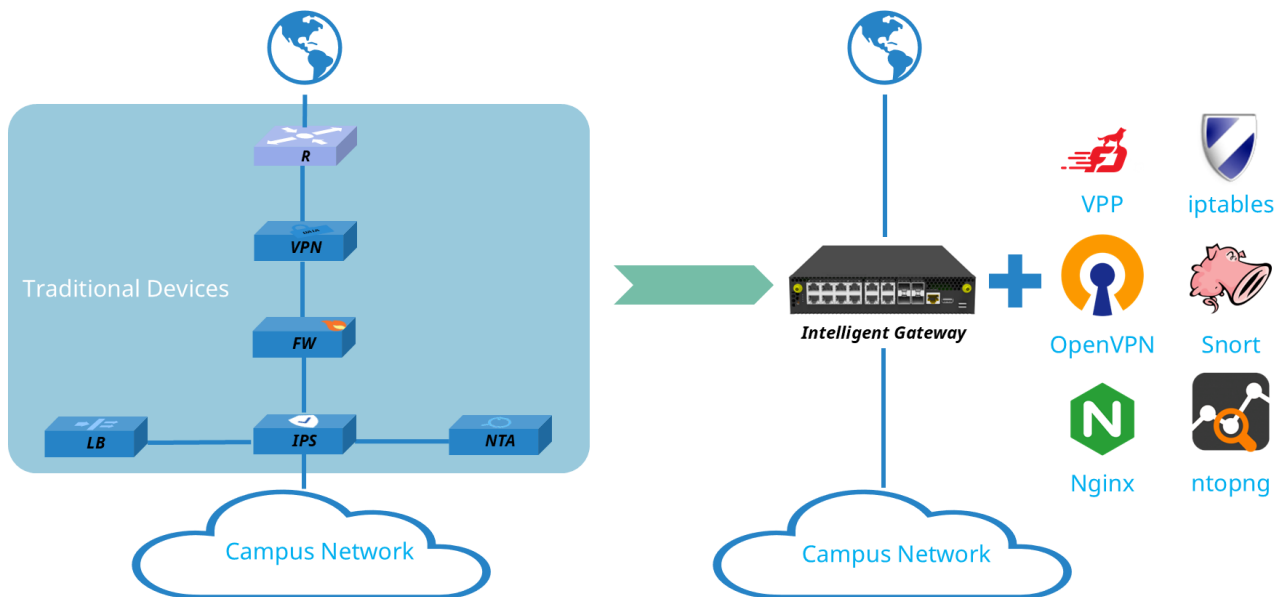

In recent years, businesses have embraced technologies like cloud computing, big data, video conferencing, live streaming, and notably, the application of AI and IoT technologies has facilitated business transformation through machine empowerment. The widespread adoption of these innovations has substantially reshaped the composition and direction of enterprise network traffic. Traditional network devices, constrained by their closed and inflexible nature, face challenges in adapting to these emerging business trends.

Traditional enterprise networks typically employ various dedicated devices to handle different functions:

- **Dedicated routers:** Responsible for routing network traffic, NAT, traffic control, QoS, and other functionalities.
- **Dedicated firewalls:** Control inbound and outbound network traffic through security rules.
- **Dedicated VPN gateways:** Authenticate remote users and facilitate encrypted communication.
- **Dedicated IDS/IPS:** Deeply analyze network traffic to prevent network attacks.
- **Dedicated load balancers:** Distribute network traffic among multiple enterprise servers.
- **Dedicated Network Traffic Analyzer (NTA):** Real-time monitoring and analysis of network traffic.
- **Dedicated Network Behavior Analyzer (NBA):** Utilizes AI and big data behavior analysis

techniques to provide advanced threat detection.

These devices each utilize dedicated hardware and software, making enterprise networks complex, expensive, and difficult to operation & maintain. To address this issue, the ET2500 adopts a Computing-Networking fusion chip architecture and a decoupled open design, allowing enterprises to use a single intelligent device to perform all of the aforementioned functions.

As a compact high-performance box only the size of a laptop and 1U in height, the ET2500 is ideal for deployment at enterprise exits as an intelligent gateway. For small businesses, a single ET2500 can handle all functions from routing and firewalling to network traffic analysis, and can even serve as a small server running various enterprise applications. For medium to large enterprises, multiple ET2500 units can be deployed as a resource pool, enabling horizontal load balancing or vertical task specialization akin to cloud computing, facilitating on-demand and elastic scheduling.

Hardware Highlight

- 8 x 2.7GHz ARM64 Neoverse N2 Core
- 16GB pluggable DDR5 SO-DIMM, up to 128G
- 4 x 10GE, 4 x 2.5GE and 8 x 1GE, optional 8 x 1GE PoE+, 4 x 2.5GE PoE++ @150W budget
- True inline crypto engine
- Optional AI hardware accelerator with 26TOPS INT8 inference performance
- Optional M.2 SSD up to 4TB
- 2 pluggable modules with M.2 form, extending support 5G/LTE, WiFi6E/7, BlueTooth5.3, GNSS, TPM(Trusted Platform Module), etc.
- Optional PTP module with 20ns accuracy and BC support, featuring holdover > 8 hours
- 60Gbps intelligent data processing for routing, firewall, IPSec and SSL/TLS
- <60 Watt with FULL configuration and workload (w/o PoE)

Application Scenarios

Based on the open hardware-software decoupled architecture, the ET2500 combines a rich array of open-source software for control plane with hardware-optimized data plane, and can connect to SSDs, 5G/LTE, WiFi6E/7, GNSS, TPM, and other devices via M.2 and USB interfaces, thereby addressing diverse application scenarios. Here are some typical scenarios that can be used individually or in combination:

■ Router: Ubuntu + VPP

- Hardware-optimized vector packet technology and DPDK accelerate data plane forwarding, delivering up to 60Gbps forwarding performance.
- Multi-WAN load balancing across Ethernet and 5G/LTE links.
- Comprehensive QoS policies for precise management of traffic from different users and applications.

■ Firewall: Ubuntu + iptables + BPFILTER

- Flexible and efficient iptables configuration suitable for a wide range of scenarios.
- GUPFW provides a simple and user-friendly GUI.
- BPFILTER leverages eBPF for advanced packet filtering and processing.

■ VPN Gateway: Ubuntu + OpenVPN/WireGuard

- Hardware-accelerated OpenVPN with encryption/decryption engine supports up to 60Gbps throughput.
- WireGuard benefits from an 8-core CPU for accelerated performance.
- Installation of the latest VPN software on demand to adapt to changing network environments.

■ IDS/IPS: Ubuntu + Snort

- Leading open-source IDS/IPS with continuously updated rule sets from its active open community.

- Hardware DPDK enhances packet processing performance and reduces latency.
- Optimized regular expression engine boosts IDS/IPS performance.

■ **Load Balancer:** Ubuntu + HAProxy + Nginx

- Optimized regular expression engine boosts load balancing performance based on domain and URL.
- Hardware DPDK improves processing speed and throughput.
- Hardware SSL engine speeds up HTTPS connections.

■ **Network Traffic Analyzer (NTA):** Ubuntu + ntopng

- Real-time traffic monitoring, protocol recognition, application analysis, historical data logging, and visual reporting capabilities.
- Intuitive GUI for visualizing and analyzing network traffic and performance metrics.
- Hardware SSL engine accelerates HTTPS traffic analysis.

Additionally, users have the flexibility to install new software or develop their own software using the built-in toolchain as needed to address additional use cases.

Operating System

- Supports Ubuntu, Debian, OpenWRT and other Linux distribution, such as CentOS, OpenSUSE, Arch Linux, AlmaLinux, Rocky Linux, Linux Mint and Elementary OS.
- Install and upgrade the OS using a USB disk with Arm Trusted Firmware and UEFI
- Embedded eBPF (extended Berkeley Packet Filter) in Linux kernel via XDP

Software Ecosystem

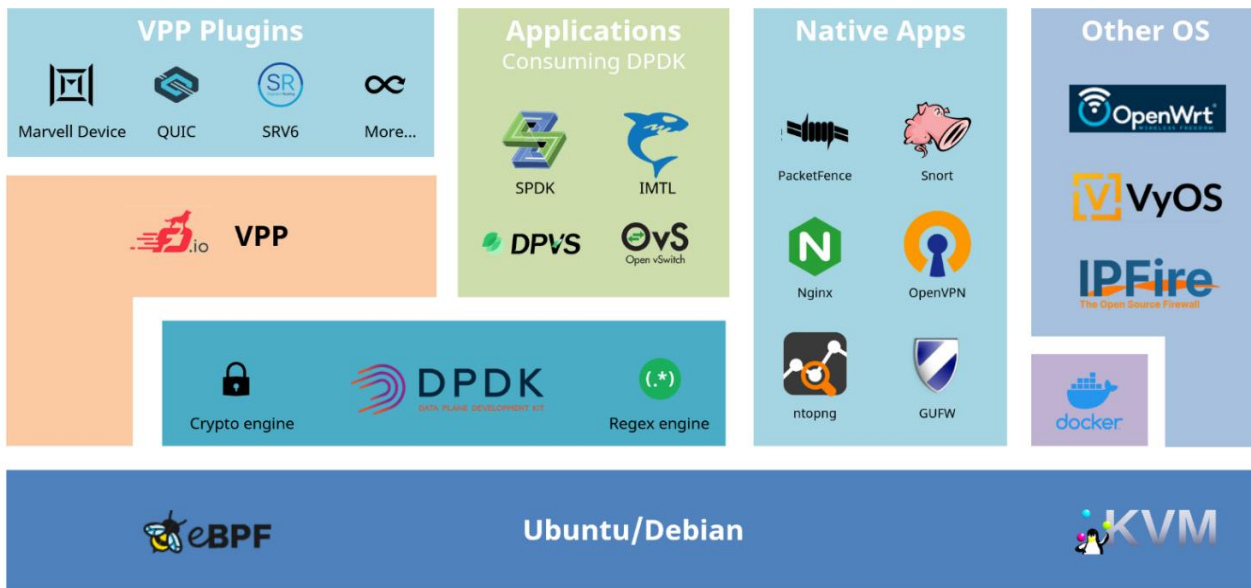

- Optimized DPDK (Data Plane Development Kit) tied to HW Acceleration
- Open-source routers, including VPP (Vector Packet Processing), OpenWRT, DD-WRT, VyOS, etc.
- Open-source firewalls, including iptables, UFW, pfSense, OPNsense, IPFire, nftables, FirewallD, Shorewall, Untangle, etc.
- Open-source VPNs, including OpenVPN, WireGuard, IPsec, L2TP, Shadowsocks, Trojan, VMess, etc.
- Open-source IDS/IPS, including Snort, Suricata, Zeek, etc.
- Open-source load balancers, including HAProxy, Nginx, Traefik, etc.
- Open-source Network Traffic Analyzers, including ntopng, Elasticsearch + Kibana + Beats, Argus, Softflowd, etc.
- Open-source projects consuming DPDK, including DPVS, Gatekeeper, Open vSwitch, SPDK, etc.
- Rich VPP plugins, including Marvel device plugin, QUIC, SRv6, LLDP, NAT64, LACP, SRTP etc.
- GCC, GDB, BinUtils, Buildroot and other tool chains
- C/C++/Python/Go/Rust/Java/Lua and other programming languages
- PyTorch/Tensorflow/TF Lite/Keras/ONNX
- Applications from other Linux distributions on Ubuntu/Debian using Docker with direct access to the host network
- Any software for ARM64 + Linux

Specifications

Product Model		ET2500
Computing	CPU	8 Core ARM64 N2 @ 2.7 GHz
	Cache	L2 8MB, L3 16MB
	RAM	16GB DDR5 SODIMM, up to 48GB
	Flash	64GB eMMC 5.1
	NVME SSD (Option)	up to 4TB, M.2 M key, share slot with AI accelerator
	SATA SSD (Option)	up to 4TB, M.2 M key, dedicated slot
	SPECint (2017)	37
AI accelerator (Factory option)	Inference performance	26TOPS@INT8
Network interface	10GE (SFP+)	4
	2.5GE (RJ45)	4
	1GE (RJ45)	8
	PoE (Option)	2.5GE(PoE++), 1GE(PoE+) ports
	WiFi (Option)	WiFi6E/7, M.2 E key
	5G/LTE (Option)	2 SIM cards, M.2 B key
	Antenna	6
Network performance	L2/L3 Switching capacity	60Gbps
	Routing capacity	60Gbps
	Firewall capacity	60Gbps
	Encryption and Decryption capacity	60Gbps
	PTP/SyncE accuracy	20ns
	PTP/SyncE holdover time	> 8hours
Misc. interface	USB	1 x USB3.1

	OOB	1 x RS232 RJ45
Electrical characteristics	Fan	2
	Power Module	1 x 150W (w/o PoE) 1 x 270W (PoE)
	Input voltage	100~240VAC
	Maximum power consumption	60W (FULL configuration and workload)
	PoE budget	150W
Dimensions	Height	1U
	Dimensions (W x H x D, mm)	220 x 44 x 310
Operating conditions	Operating temperature	0 - 45°C
	Relative humidity	5% - 95% (non-condensing)

Hardware Panel

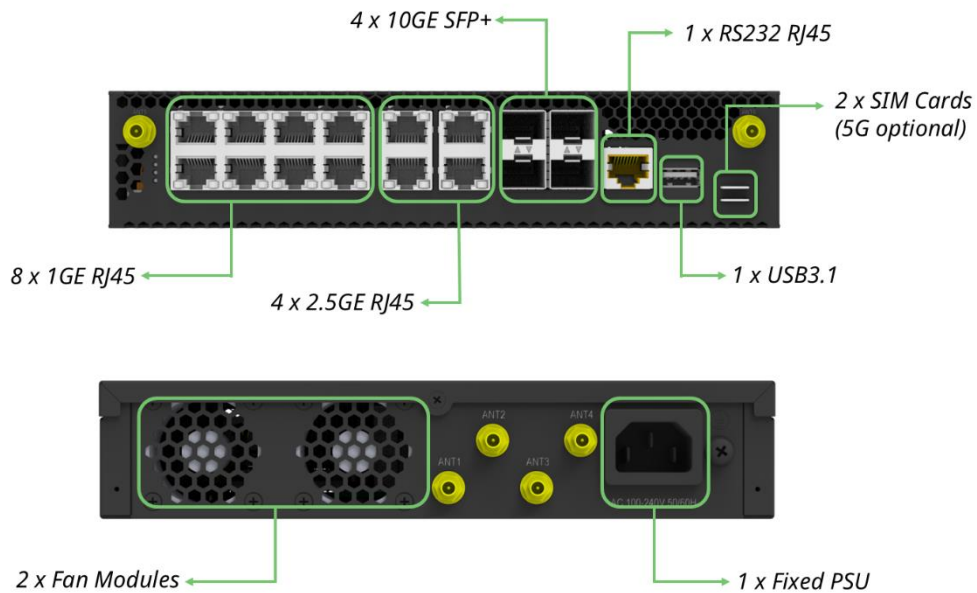

System Architecture

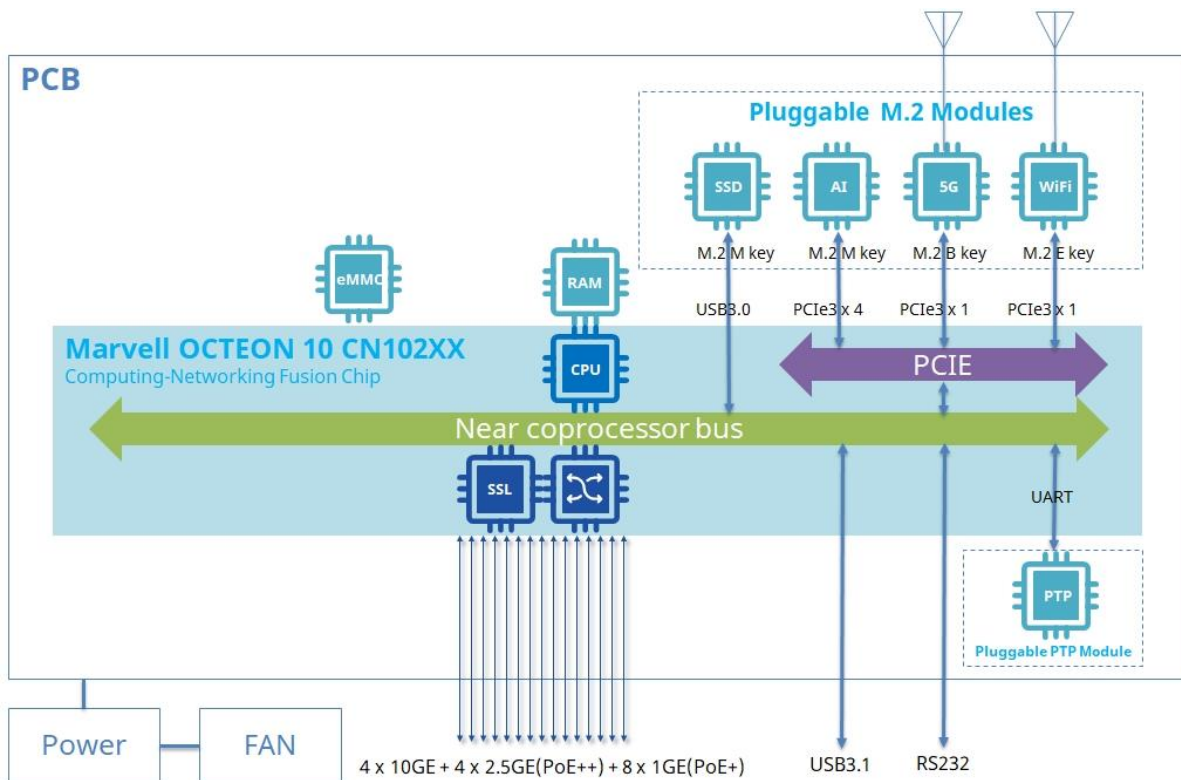

ET2500 Open Intelligent Gateway system architecture

Order Information

Part Number	Description
ET2500	Open Smart Gateway, 8 Core ARM64 N2 CPU, 16GB DDR5, 64GB eMMC, 4 x 10GE + 4 x 2.5GE + 8 x 1GE, Switch, 150W Power
ET2500-SWP	Open Smart Gateway, 8 Core ARM64 N2 CPU, 16GB DDR5, 64GB eMMC, 4 x 10GE + 4 x 2.5GE + 8 x 1GE, 4 x PoE@150W on 2.5GE/1GE ports, 270W Power
Optional components and spares	
AI-M2-26TOPS	AI Accelerator, 26 Tera-Operations Per Second, M.2 M Key 2280, PCIe3 x4, 2.5W
AI-M2-40TOPS	AI Accelerator, 40 Tera-Operations Per Second, 8GB LPDDR4 ON-Module DDR, M.2 M Key 2280, PCIe3 x4, 3.5W

SSD-M2-NVME-1TB	SSD,1TB, NVME, M.2 M Key 2280, PCIe3 x4
SSD-M2-NVME-2TB	SSD,2TB, NVME, M.2 M Key 2280, PCIe3 x4
SSD-M2-NVME-4TB	SSD,4TB, NVME, M.2 M Key 2280, PCIe3 x4
SSD-M2-SATA-1TB	SSD, 1TB, SATA, M.2 M Key, USB3.0
SSD-M2-SATA-2TB	SSD, 2TB, SATA, M.2 M Key, USB3.0
SSD-M2-SATA-4TB	SSD, 4TB, SATA, M.2 M Key, USB3.0
5G-M2-5Gbps	5G Module, PCIe 3x1, M.2 B key, 5G NR, LTE, GNSS, 5.0Gbps (DL) / 650Mbps (UL)
WiFi7-M2-9Gbps	WiFi6E/7 Module, PCIe 3x1, M.2 E key, Tri-Band 802.11be/ax, Bluetooth 5.3, 6-Stream 9.3Gbps
PTP-20ns	PTP module, 20ns accuracy, BC support with holdover > 8hours
SVC-Basic-1Y-ET	Basic H/W Service and Warranty

Warranty and Service Support

Asterfusion ET2500 gateway come with 2-year Basic H/W service and warranty.

To acquire more info about company, products, and solutions: www.cloudswit.ch

Sales: bd@cloudswit.ch

Business Hotline: +86-0512-62982976

