

Asterfusion 100G QSFP28 DR1 Duplex LC SMF 500m Optical Transceiver

Features

- 4x25Gb/s electrical NRZ modulation
- 1x100Gb/s optical PAM4 modulation
- Convert 1 channel of 100Gbps (PAM4) optical signal to/from 4 channels of 25Gbps (NRZ) electrical data
- Maximum 500m on SMF with FEC
- Power consumption <4.5W
- Hot Pluggable QSFP28 form factor
- Duplex LC connector receptacle
- Built-in digital diagnostic functions
- Compliant with CMIS
- Operating case temperature 0°C to +70°C
- RoHS compliant
- IEEE802.3cd 100GBASE-DR Specification compliant

Overview

The Asterfusion QSFP28 100G DR1 optical transceiver module is designed for 100 Gigabit Ethernet applications. It supports data transmission up to 500m over SMF with FEC. The 100G PAM4 to NRZ gearbox digital signal processor (DSP) improves signal processing and supports 106.25 Gb/s aggregate data speeds. This module can convert 4 channels of 25Gbps (NRZ) electrical input data to 1 channel of 100Gbps (PAM4) optical signal, and also can convert 1 channel of 100Gbps (PAM4) optical signal to 4 channels of 25Gbps (NRZ) electrical output data.

Its energy efficiency comes from its low power consumption of 4.5 watts and commercial temperature range of 0 to 70 degrees Celsius. Additionally, it offers stable connections in the data center, 4:1 breakout with 400G-DR4 or 8:1 breakout with 800G-2xDR4/DR8 switches or routers.

The form factor of OT-100G-QSFP-DR1 is QSFP28 and the optical interface uses Duplex LC connectors. It is compatible with the Common Management Interface Specification (CMIS), QSFP28 Multi-Source Agreement (MSA), and the IEEE802.3cd 100GBASE-DR standards.

Product Applications

- AI Inference Fabric
- Data Center Fabric
- HPC Fabric
- Campus Spine-Leaf connection
- High-speed Servers
- Ethernet Storage Fabric

Block Diagram

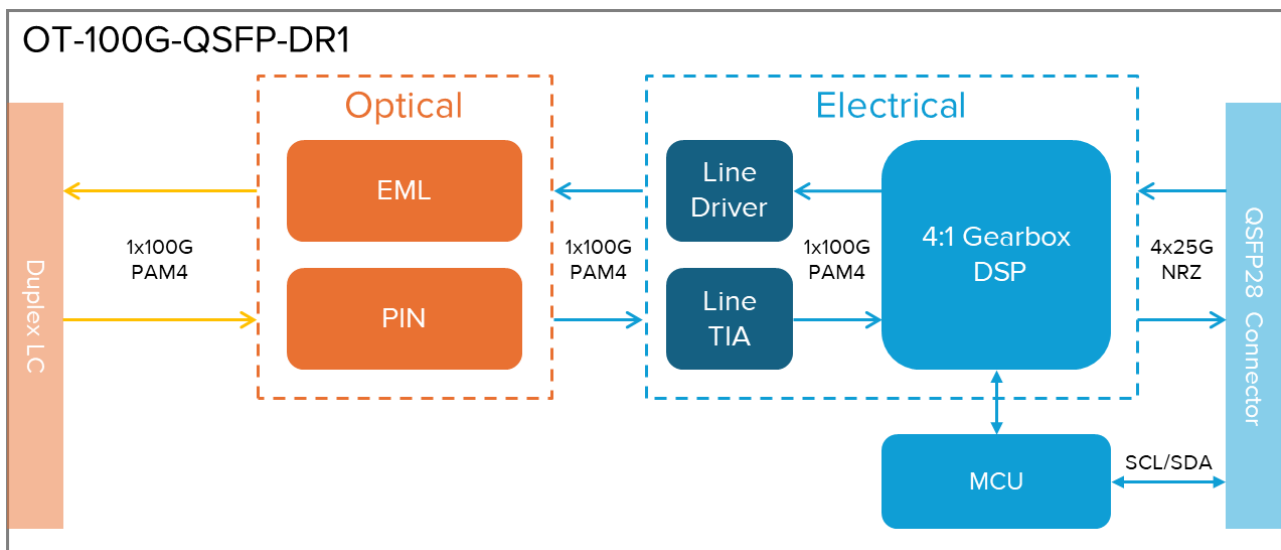

Figure 1 The 100G QSFP28 DR1 Optical Transceiver Block Diagram

Networking

The transceiver can connect to 100/400G/800G DR transceivers.

1. Connect two 100G-port switches with Duplex LC SMF cable.



Figure 2 Connect two 100G-port switches

2. Connect to a 400G-port switch with MPO-12 to 4 Duplex LC SMF breakout cable.

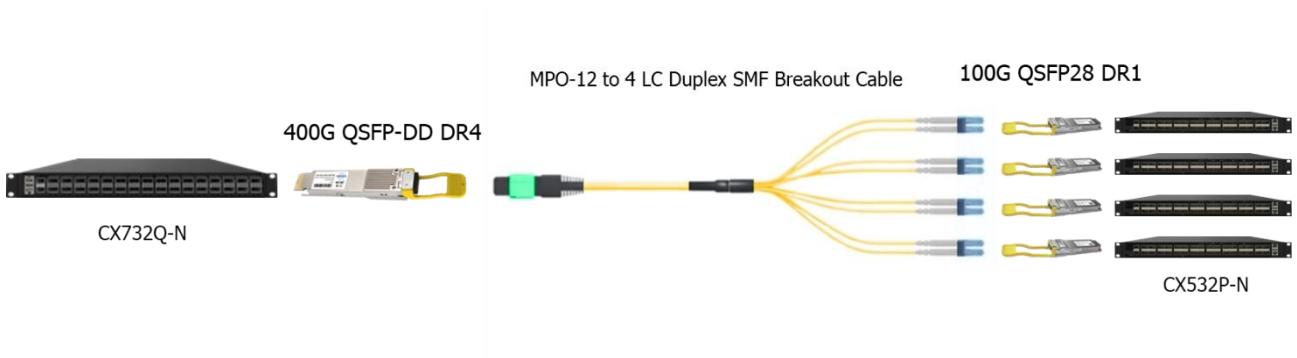

Figure 3 100G DR1 to 400G DR4

3. Connect to an 800G-port switch with two MPO-12 to 4 Duplex LC SMF breakout cable.

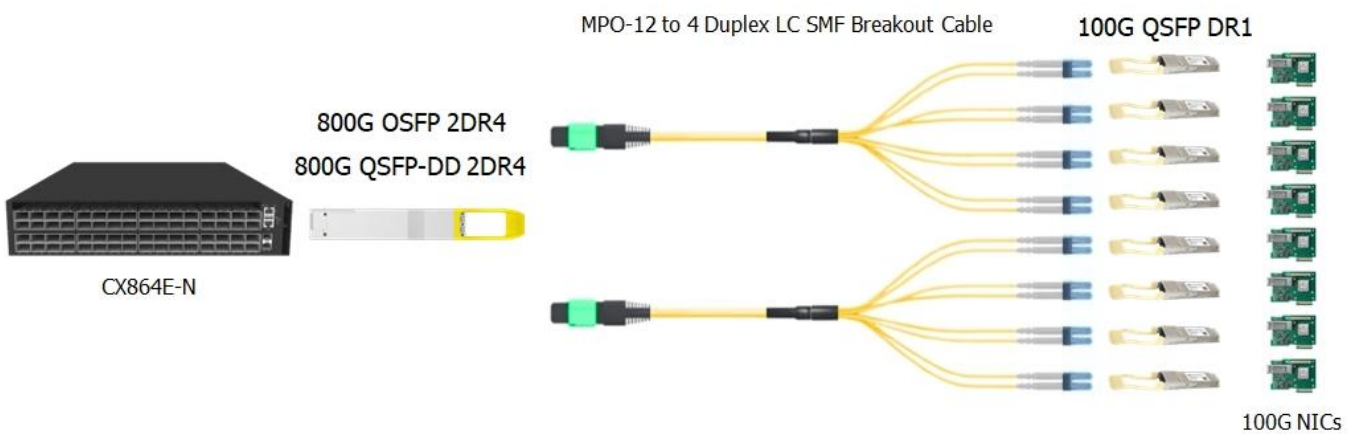

Figure 4 100G DR1 to 800G 2xDR4

4. Connect to an 800G-port switch with one MPO-16 to 8 Duplex LC SMF breakout cable.

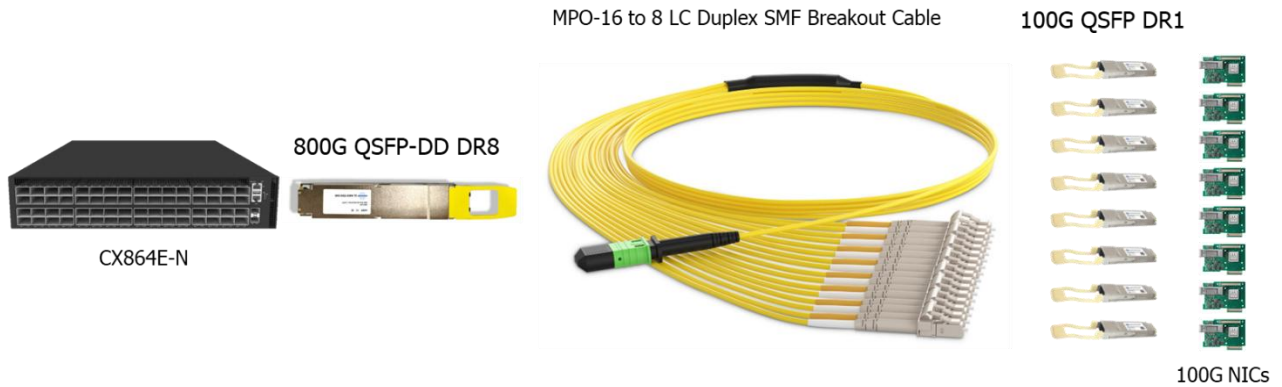

Figure 5 100G DR1 to 800G DR8

Specifications

Electrical Specifications

Parameter	Symbol	Min.	Typ.	Max.	Unit
Power Consumption				4.5	W
Supply Current	Icc			1.36	A
Pre-FEC Bit Error Ratio (BER)				2.4E-4	
Transmitter (each Lane)					
Overload Differential Voltage pk-pk	TP1a	900			mV
Common Mode Voltage (Vcm)	TP1	-350		2850	mV [1]
Differential Termination Resistance Mismatch	TP1			10	%
Differential Return Loss (SDD11)	TP1			See CEI 28G-VSR Equation 13-19	dB
Common Mode to Differential Conversion and Differential to Common Mode Conversion (SDC11, SCD11)	TP1	See CEI 28G-VSR Section 13.3.11.2.1			
Receiver (each Lane)					

Differential Voltage, pk-pk	TP4			900	mV
Common Mode Voltage (Vcm)	TP4	-350		2850	mV
Common Mode Noise, RMS	TP4	3.5		17.5	mV
Differential Termination Resistance Mismatch	TP4			10	%
Differential Return Loss (SDD22)	TP4			SeeCEI 28G-VSR Equation 13-19	dB
Common Mode to Differential Conversion and Differential to Common Mode Conversion (SDC22, SCD22)	TP4			SeeCEI 28G-VSR Equation 13-21	dB
Common Mode Return Loss (SCC22)	TP4			-2	dB [2]
Transition Time, 20 to 80%	TP4	9.5			ps
Vertical Eye Closure (VEC)	TP4			5.5	dB
Eye Width at 10-15 probability (EW15)	TP4	0.57			UI
Eye Height at 10-15 probability (EH15)	TP4	228			mV

Notes:

1. Vcm is generated by the host. Specification includes effects of ground offset voltage.
2. From 250MHz to 30GHz.

Optical Characteristics

Transmitter Characteristics

Parameter	Symbol	Min.	Typ.	Max.	Unit	Notes
Center Wavelength	λ_t	1304.5		1317.5	nm	
Side-mode suppression ratio	SMSR	30			dB	
Average launch power, each lane	P_{AVG}	-2.9		4	dBm	[1]

Outer Optical Modulation Amplitude (OMA_{outer}), each lane	P_{OMA}	-0.8		4.2	dBm	[2]
Launch Power in OMA_{outer} minus TDECQ for $ER \geq 5dB$ for $ER < 5dB$		-2.2 -1.9			dBm	
Transmitter and Dispersion Eye Closure for PAM4 (TDECQ)	TDECQ			3.4	dB	
Average launch power of OFF transmitter, each lane				-15	dBm	
Extinction ratio	ER	3.5			dB	
Optical return loss tolerance				15.5	dB	
Transmitter reflectance				-26	dB	

Receiver Characteristics

Parameter	Symbol	Min.	Typ.	Max.	Unit	Notes
Center Wavelength	λ_r	1304.5		1317.5	nm	
Damage threshold		5			dBm	[3]
Average power at receiver input, each lane		-5.9		4	dBm	[4]
Receive power, each lane (OMA_{outer})				4.2	dBm	
Receiver reflectance				-26	dB	
Receiver sensitivity (OMA_{outer})	SOMA			$\max(-3.9, \text{SECQ} - 5.3)$	dBm	[5]
Stressed Receiver Sensitivity (OMA_{outer})				-1.9	dBm	[6]
LOS Assert	LOS_A	-15			dBm	
LOS De-Assert	LOS_D			-8.9	dBm	
LOS Hysteresis		0.5			dB	

Notes:

1. Average launch power (min) is informative and not the principal indicator of signal strength. A transmitter with launch power below this value cannot be compliant; however, a value above this does not ensure compliance.

2. Even if the TDECQ < 1.4dB for an extinction ratio of ≥ 5dB or TDECQ < 1.1dB for an extinction ratio of < 5dB, the OMA_{outer} (min) must exceed the minimum value specified here.
3. Average receive power (min) is informative and not the principal indicator of signal strength. A received power below this value cannot be compliant; however, a value above this does not ensure compliance.
4. The receiver shall be able to tolerate, without damage, continuous exposure to a modulated optical input signal having this power level on one lane. The receiver does not have to operate correctly at this input power.
5. Receiver sensitivity (OMA_{outer}) (max) is informative and is defined for a transmitter with a value of SECQ up to 3.4 dB. It should meet Equation (1), which is illustrated in Figure 6

$$RS = \max(-3.9, SECQ - 5.3) \text{ dBm} \quad (1)$$

Where:

RS is the receiver sensitivity, and

SECQ is the SECQ of the transmitter used to measure the receiver sensitivity

6. Measured with conformance test signal at TP3 for the BER equal to 2.4x10⁻⁴.

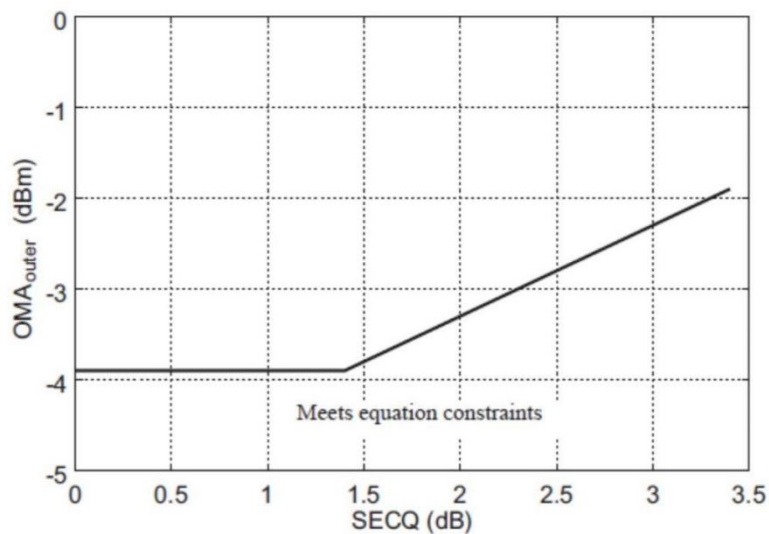

Figure 6 Receiver sensitivity

Optical Interface Lanes and Assignment

The optical interface port is a Duplex LC receptacle. The transmit and receive optical lanes shall occupy the positions depicted in Figure 7.

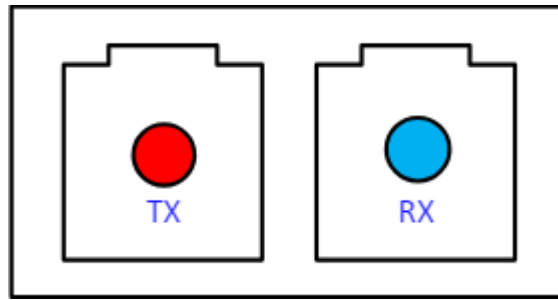

Figure 7 Optical Receptacle and Channel Orientation

Mechanical Dimensions

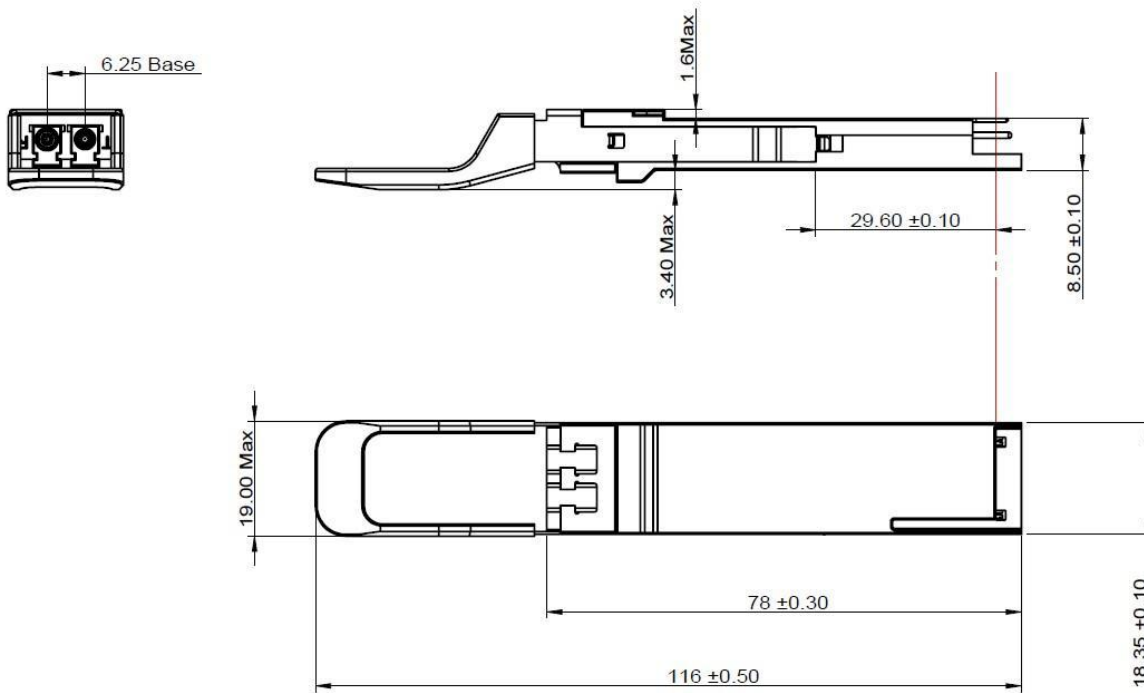

Figure 8 Mechanical Specifications (mm)

Absolute Maximum Ratings

Parameter	Symbol	Conditions	Min.	Max.	Unit
Storage Temperature	TStorage		-40	+85	°C
Relative Humidity	RH		0	+85	%

Recommended Operating Conditions

PIN Description

Case Temperature	T_c		0		70	°C
Power Supply Voltage	V_{cc}		3.135	3.3	3.465	V
Electrical Data Rate, each Lane (NRZ)				25.78125		Gbps
Optical Data Rate (PAM4)				53.125		GBd
Data Rate Accuracy			-100		100	ppm
Operating Distance	D				500	m

It complies with the 100G QSFP28 MSA Specification.

QSFP28 Pin Description

PIN	Logic	Symbol	Name/Description	Note
1		GND	Ground	
2	CML-I	Tx2n	Transmitter Inverted Data Input	
3	CML-I	Tx2p	Transmitter Non-Inverted Data output	
4		GND	Ground	
5	CML-I	Tx4n	Transmitter Inverted Data Input	
6	CML-I	Tx4p	Transmitter Non-Inverted Data output	
7		GND	Ground	
8	LVTTL-I	ModSelL	Module Select	
9	LVTTL-I	ResetL	Module Reset	
10		VccRx	+ 3.3V Power Supply Receiver	
11	LVCOS-I/O	SCL	2-Wire Serial Interface Clock	
12	LVCOS-I/O	SDA	2-Wire Serial Interface Data	
13		GND	Ground	
14	CML-O	Rx3p	Receiver Non-Inverted Data Output	
15	CML-O	Rx3n	Receiver Inverted Data Output	
16		GND	Ground	
17	CML-O	Rx1p	Receiver Non-Inverted Data Output	
18	CML-O	Rx1n	Receiver Inverted Data Output	
19		GND	Ground	
20		GND	Ground	

21	CML-O	Rx2n	Receiver Inverted Data Output	
22	CML-O	Rx2p	Receiver Non-Inverted Data Output	
23		GND	Ground	
24	CML-O	Rx4n	Receiver Inverted Data Output	
25	CML-O	Rx4p	Receiver Non-Inverted Data Output	
26		GND	Ground	
27	LVTTL-O	ModPrsL	Module Present	
28	LVTTL-O	IntL	Interrupt	
29		VccTx	+3.3 V Power Supply transmitter	
30		Vcc1	+3.3 V Power Supply	
31	LVTTL-I	LPMode	Low Power Mode	
32		GND	Ground	
33	CML-I	Tx3p	Transmitter Non-Inverted Data Input	
34	CML-I	Tx3n	Transmitter Inverted Data Output	
35		GND	Ground	
36	CML-I	Tx1p	Transmitter Non-Inverted Data Input	
37	CML-I	Tx1n	Transmitter Inverted Data Output	
38		GND	Ground	

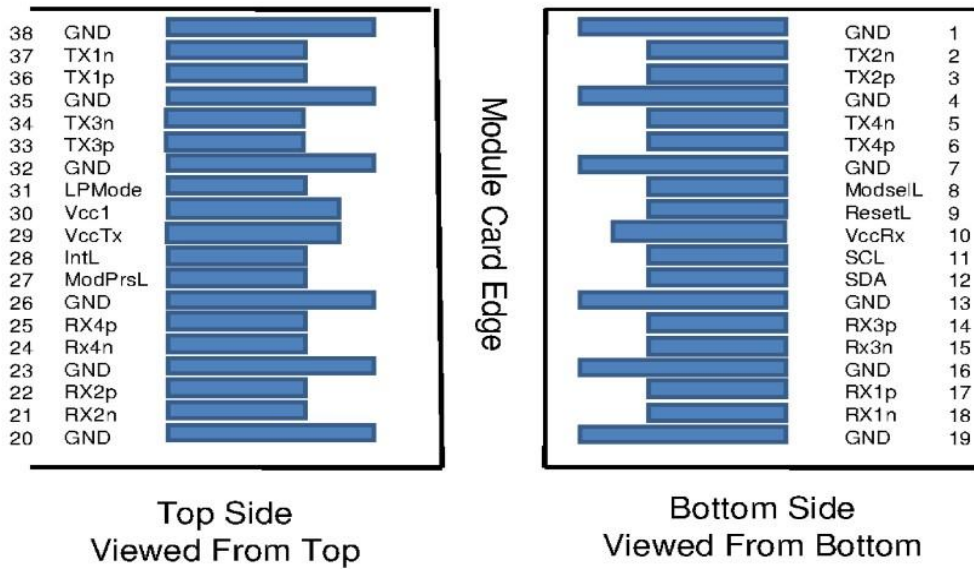

Figure 9 Electrical Pin-out Details

Digital Diagnostic Specification

Parameter	Accuracy	Unit
Internally measured transceiver temperature	+/-3	deg.C
Supply Voltage Monitor Absolute Error	+/-0.1	V
Bias Current Monitor	+/-10%	mA
TX Power Monitor Absolute Error	+/-2	dB
RX Power Monitor Absolute Error	+/-2	dB

Order Information

Part Number	Description
OT-100G-QSFP-DR1	100G, QSFP28, DR1, Duplex LC, 1310nm SMF, 500m

Warranty and Service Support

Asterfusion optical transceivers come with 2-year Basic H/W service and warranty.

To acquire more info about company, products, and solutions: www.cloudswit.ch
Sales: bd@cloudswit.ch
Business Hotline: +86-0512-62982976

