

# Asterfusion 800G OSFP DR8 MPO-16 APC MMF 500m Optical Transceiver

## Features

- 8 x 106.25Gbps PAM4 electrical interface
- 8 x 106.25Gbps PAM4 optical interface
- Maximum link length of 500m SMF
- Hot Pluggable OSFP form factor
- Power consumption <16W
- MPO-16 connector receptacles
- Built-in digital diagnostic functions
- Compliant with CMIS 5.1
- +3.3 V power supply
- Operating case temperature 0°C to +70°C
- Class 1 laser safety
- ROHS Compliant(lead free)

## Overview

The Asterfusion 800G OSFP DR8 transceiver module is a low-power, high-density, pluggable OSFP module designed for 800 Gigabit Ethernet applications. The transceiver module is compliant with OSFP MSA, 800G Pluggable MSA, IEE 802.3ck and IEEE 802.3df standards. The optical module supports 8×106.25Gbps (total 850Gbps) data rates and achieves a maximum link length of 500 meters over single-mode fiber (SMF). The module supports single-mode fiber systems with a nominal wavelength of 1310 nm. The optical interface uses 16-fiber MTP (MPO) connectors. It supports digital diagnostic functions and is fully compatible with the Common Management Interface Specification (CMIS) 5.1.

## Product Applications

- AI Training Fabric
- AI Inference Fabric
- Data Center Fabric
- Ethernet Storage Fabric
- HPC (High Performance Computing)
- Supercomputer
- Telecom Backbone

## Block Diagram

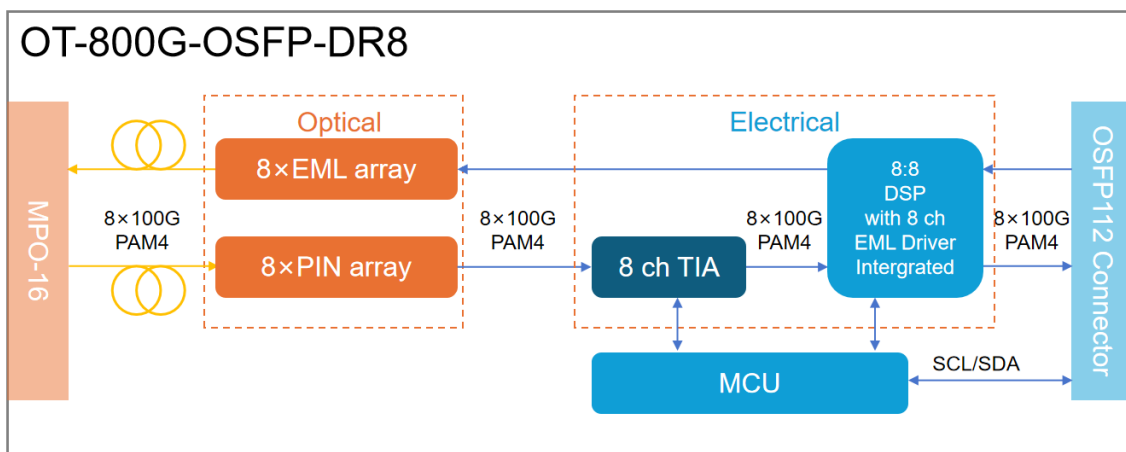

Figure 1. 800G OSFP112 DR8 Optical Transceiver Block Diagram

## Networking

The transceiver can connect 800G-port switches with MPO-16 single-mode fiber cable.

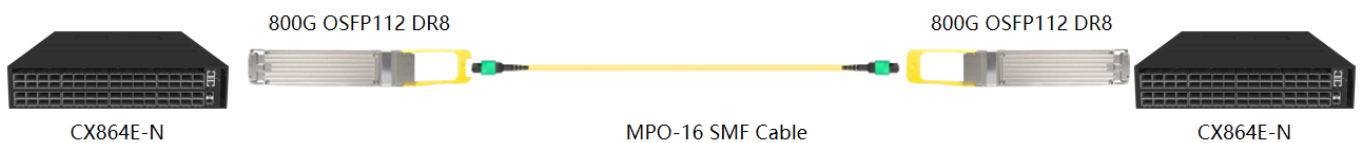

Figure 2. Connect two 800G-port switches

Connect 8x100G smartNICs to 800G-port switches with MPO-16 to 8xDuplex LC SMF breakout cable.

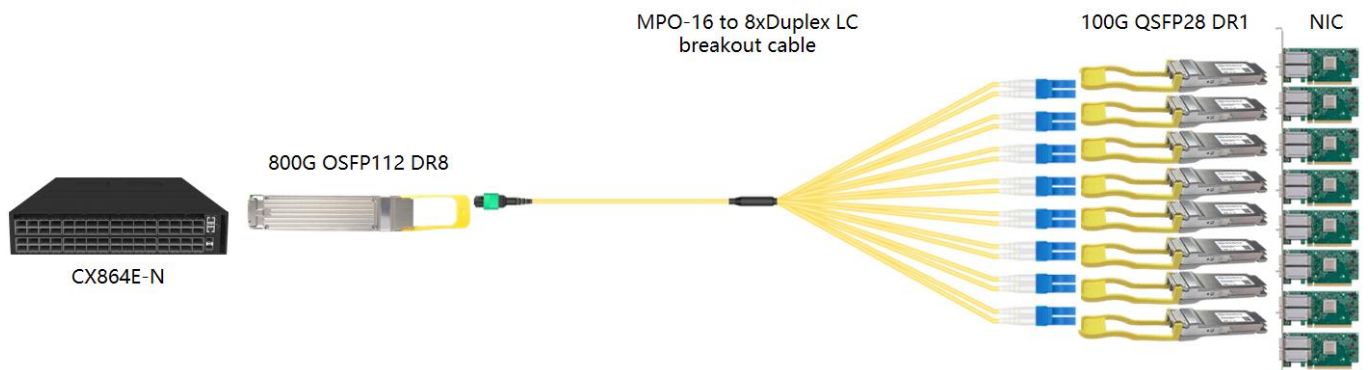

Figure 3. Connect 800G-port switches to NICs

## Specifications

### Electrical Specifications

Parameter	Symbol	Min	Typ	Max	Units	Notes
Power On Initialization Time	$T_{init}$			2000	ms	
Pre-FEC Bit Error Ratio	BER			2.4E-4		
Post-FEC Bit Error Ratio	BER			1.0E-15		
Transmitter Characteristics						
Parameter	Symbol	Min	Typ	Max	Units	Notes
Signaling Speed, each lane			53.125		GBd	
Signaling Speed Tolerance		-100		+100	ppm	
Differential pk-pk input voltage tolerance	$V_{in,pp}$	750			mV	
AC common-mode RMS voltage tolerance		25			mV	
Differential Input Impedance	$Z_{in}$	90	100	100	Ohms	
Effective return loss	ERL	8.5			dB	
Single-ended voltage tolerance range		-0.4		3.3	V	
DC Common Mode Voltage		-0.35		2.85	V	
Receiver Characteristics						

Parameter	Symbol	Min	Typ	Max	Units	Notes
Signaling Speed, each lane			53.125		GBd	
Signaling Speed Tolerance		-100		+100	ppm	
Differential pk-pk output voltage tolerance	$V_{out,pp}$					
Short mode				600	mV	
Long mode				845		
Eye Height	EH	15			mV	
Differential Output Impedance	$Z_{out}$	90	100	110	Ohms	
Transition Time, 20% to 80%	$T_r, T_f$	8.5			ps	
DC Common Mode Voltage		-0.35		2.85	V	
AC Common Mode output Voltage (RMS)		25			mV	

## Optical Characteristics

Transmitter Characteristics						
Parameter	Symbol	Min	Typ	Max	Units	Notes
Centre Wavelength	$\lambda_c$	1304.5	1311	1317.5	nm	
Side-mode suppression ratio	SMSR	30	-	-	dB	
Average launch power, each lane	$P_{out}$	-2.9	-	4.0	dBm	
Outer Optical Modulation Amplitude	$OMA_{outer}$					
for $TECQ < 1.4dB$		-0.8		4.2	dBm	
for $1.4dB \leq TECQ \leq 3.4dB$		$2.2 + TDECQ$				
Extinction Ratio	ER	3.5	-	-	dB	
Average launch power TX Off	$P_{off}$			-15	dBm	
Transmitter and dispersion eye closure for PAM4 (TDECQ), each lane	TDECQ			3.4	dB	
Transmitter eye closure for PAM4	TECQ			3.4	dB	

TDECQ-TECQ				2.5	dB	
Transmitter transition time				17	ps	
Relative Intensity Noise	RIN			-136	dB/Hz	
Optical Return Loss	ORTL			21.4	dB	
Reflectance				-26	dB	
Receiver Characteristics						
Parameter	Symbol	Min	Typ	Max	Units	Notes
Centre Wavelength	$\lambda_c$	1304.5	1311	1317.5	nm	
Damage Threshold		5			dBm	
Average Receiver power, each lane		-5.9		4	dBm	
Receiver Power ( $OMA_{outer}$ )				4.2	dBm	
Receiver Reflectance				-26	dB	
Receiver Sensitivity in $OMA_{outer}$ for $TECQ < 1.4dB$ for $1.4dB \leq TECQ \leq 3.4dB$				-3.9 5.3+TECQ	dBm	1
Stressed Receiver Sensitivity ( $OMA_{outer}$ )				-1.9	dBm	
Conditions of Stressed Receiver Sensitivity Test						
Stressed Eye Closure, lane under test	SECQ		3.4		dB	
$OMA_{outer}$ of Each Aggressor Lane			4.2			

**Note:**

1. Measured with conformance test signal at TP3 for BER = 2.4E-4 Pre-FEC.

## Optical Interface Lanes and Assignment

The optical interface port is MPO-16APC receptacle. The transmit and receive optical lanes shall occupy the positions depicted in Figure 5.

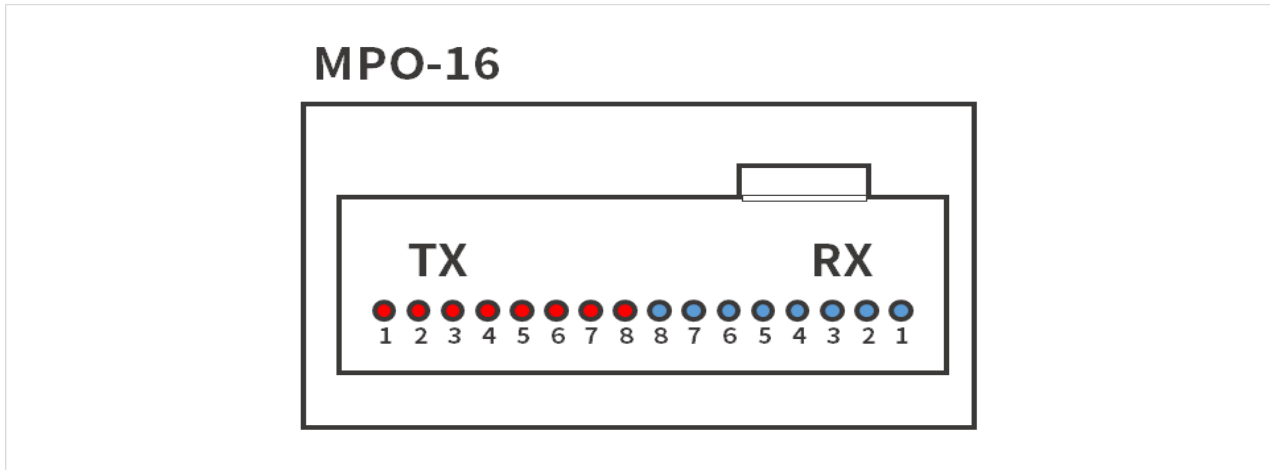

Figure 4. Optical Receptacle and Channel Orientation

## Mechanical Dimensions

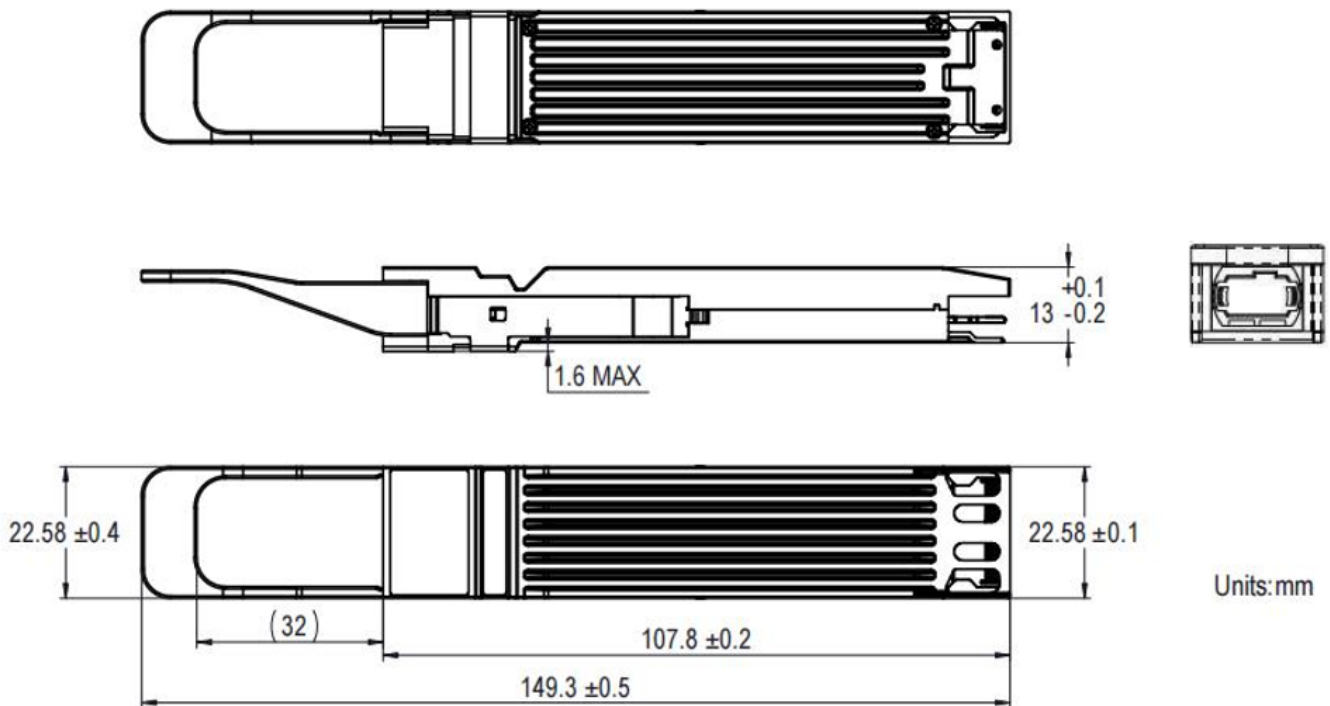

Figure 5. Mechanical Specifications (mm)

## Absolute Maximum Ratings

Parameter	Symbol	Min	Max	Units
Supply Voltage	V <sub>cc</sub>	-0.5	3.6	V
Input Voltage	V <sub>in</sub>	-0.3	V <sub>cc</sub> +0.5	V
Storage Temperature	T <sub>st</sub>	-40	85	°C
Case Operating Temperature	T <sub>op</sub>	0	70	°C
Humidity(non-condensing)	Rh	15	85	%

## Recommended operating environment

Parameter	Symbol	Min	Typ	Max	Units
Supply Voltage	V <sub>cc</sub>	3.135	3.3	3.465	V
Power Supply Current	I <sub>cc</sub>			5750	mA
Operating Case temperature	T <sub>op</sub>	0		70	°C
Humidity	Rh	15		85	%
Power Dissipation	P <sub>m</sub>			18	W
I2C Clock Frequency			100	400	kHz

## PIN Description

The optical transceiver complies with the OSFP MSA Specification, see [www.osfpmsa.org](http://www.osfpmsa.org) .

## OSFP Pin Description

PIN	Logic	Symbol	Name/Description	Direction	Plug Sequence
1		GND	Ground		1
2	CML-I	TX2p	Transmitter Data Non- Inverted	Input from Host	3
3	CML-I	TX2n	Transmitter Data Inverted	Input from Host	3
4		GND	Ground		1
5	CML-I	TX4p	Transmitter Data Non- Inverted	Input from Host	3



6	CML-I	TX4n	Transmitter Data Inverted	Input from Host	3
7		GND	Ground		1
8	CML-I	TX6p	Transmitter Data Non- Inverted	Input from Host	3
9	CML-I	TX6n	Transmitter Data Inverted	Input from Host	3
10		GND	Ground		1
11	CML-I	TX8p	Transmitter Data Non- Inverted	Input from Host	3
12	CML-I	TX8n	Transmitter Data Inverted	Input from Host	3
13		GND	Ground		1
14	LVC MOS-I/O	SCL	2-wire Serial interface clock	Bi-directional	3
15		VCC	+3.3V Power	Power from Host	2
16		VCC	+3.3V Power	Power from Host	2
17	Multi-Level	LPWn/PRSn	Low-Power Mode / Module Present	Bi-directional	3
18		GND	Ground		1
19	CML-O	RX7n	Receiver Data Inverted	Output to Host	3
20	CML-O	RX7p	Receiver Data Non-Inverted	Output to Host	3
21		GND	Ground		1
22	CML-O	RX5n	Receiver Data Inverted	Output to Host	3
23	CML-O	RX5p	Receiver Data Non-Inverted	Output to Host	3
24		GND	Ground		1
25	CML-O	RX3n	Receiver Data Inverted	Output to Host	3
26	CML-O	RX3p	Receiver Data Non-Inverted	Output to Host	3
27		GND	Ground		1
28	CML-O	RX1n	Receiver Data Inverted	Output to Host	3
29	CML-O	RX1p	Receiver Data Non-Inverted	Output to Host	3
30		GND	Ground		1
31		GND	Ground		1
32	CML-O	RX2p	Receiver Data Non-Inverted	Output to Host	3
33	CML-O	RX2n	Receiver Data Inverted	Output to Host	3
34		GND	Ground		1
35	CML-O	RX4p	Receiver Data Non-Inverted	Output to Host	3
36	CML-O	RX4n	Receiver Data Inverted	Output to Host	3
37		GND	Ground		1
38	CML-O	RX6p	Receiver Data Non-Inverted	Output to Host	3
39	CML-O	RX6n	Receiver Data Inverted	Output to Host	3
40		GND	Ground		1
41	CML-O	RX8p	Receiver Data Non-Inverted	Output to Host	3
42	CML-O	RX8n	Receiver Data Inverted	Output to Host	3

43		GND	Ground		1
44	Multi-Level	INT/RSTn	Module Interrupt / Module Reset	Bi- directional	3
45		VCC	+3.3V Power	Power from Host	2
46		VCC	+3.3V Power	Power from Host	2
47	LVC MOS-I/O	SDA	2-wire Serial interface data	Bi-directional	3
48		GND	Ground		1
49	CML-I	TX7n	Transmitter Data Inverted	Input	3
50	CML-I	TX7p	Transmitter Data Non- Inverted	Input from Host	3
51		GND	Ground		1
52	CML-I	TX5n	Transmitter Data Inverted	Input from Host	3
53	CML-I	TX5p	Transmitter Data Non- Inverted	Input from Host	3
54		GND	Ground		1
55	CML-I	TX3n	Transmitter Data Inverted	Input from Host	3
56	CML-I	TX3p	Transmitter Data Non- Inverted	Input from Host	3
57		GND	Ground		1
58	CML-I	TX1n	Transmitter Data Inverted	Input from Host	3
59	CML-I	TX1p	Transmitter Data Non- Inverted	Input from Host	3
60		GND	Ground		1

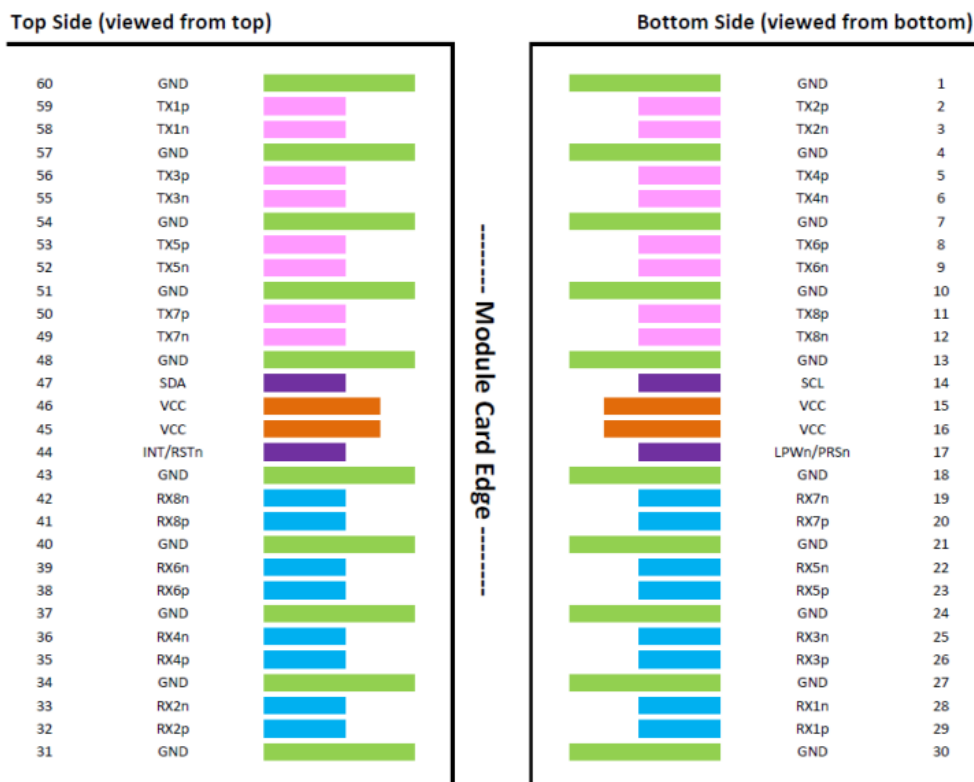

Figure 6. Electrical Pin-out Details

## Regulatory Compliance

Asterfusion OT-800G-OSFP-DR8 transceivers are Class 1 Laser Products. They are certified per the following standards:

Feature	Standard
Radiated Emissions	EMC Directive 2014/30/EU EN 55032 CISPR 32 FCC rules 47 CFR Part 15 ICES-003 VCCI-CISPR 32 AS/NZS CISPR 32
Radiated Immunity	EMC Directive 2014/30/EU EN 55035 CISPR 35 IEC/EN 61000-4-3
RoHS	EU RoHS (2011/65/ EU & (EU) 2015/863) & UK RoHS EN IEC 63000:2018 & BS EN IEC 63000:2018
Flammability (PCB)	UL Class 94 V-0

## Order Information

Part Number	Description
OT-800G-OSFP-DR8	800G, OSFP112, DR8, MPO-16 APC, 1310nm SMF, 500m/OS2, Finned Top

## Warranty and Service Support

Asterfusion optical transceivers come with 2-year Basic H/W service and warranty.

To acquire more info about company, products, and solutions: [www.cloudswit.ch](http://www.cloudswit.ch)  
Sales: [bd@cloudswit.ch](mailto:bd@cloudswit.ch)  
Business Hotline: +86-0512-62982976

